



1502xi
2502xi
3502xi
5002xi

KACO blueplanet 02xi series grid-tied inverters

Performance

High efficiency:	95.5% CEC efficiency on all 02xi series inverters ensures low energy losses
Wide MPPT range:	Highest string sizing flexibility with all modules and temperature ranges
Low start-up voltage:	KACO inverters wake up earlier and work longer than the competition
Designed for max. ROI:	Newest generation IGBTs and advanced MPPT algorithms

Ease of installation

easy install T-bracket:	Minimizes mounting process to approximately 15 minutes
Lockable DC/AC disconnect:	Save up to \$150 with the pre-wired & separable integrated disconnects
Multiple knock-outs:	Knock-outs on bottom, sides and back offer great installation flexibility
Connection box:	Avoid costly channel raceways by directly connecting multiple inverters
Reduced weight:	KACO inverters are up to 50% lighter than comparably sized inverters
Reduced side clearance:	No fan cooling outlets on the sides
Field selectable voltages:	Use the same inverter in 208V, 220V or 240V grid settings

Reliability

History:	KACO has been manufacturing power electronics for more than 60 years
Experience:	More than 2.5GW of inverters worth about \$1 billion installed worldwide
Split architecture design:	Power electronics are protected in a separate chamber
Sealed outdoor enclosure:	Protects power electronics from insects, dust, humidity and ocean air
DC reverse polarity protection:	Avoids potential damage to inverter caused by mis-wiring during installation
Redundant power capacitors:	Increases the lifetime of your inverter
Convection cooling:	No moving parts increases the uptime of your PV system

Monitoring

KACO proLOG: Monitor up to 32 inverters as well as multiple sensors

KACO watchDOG: Integrated monitoring card decreases costs and increases reliability to give you the most innovative monitoring solution

easyLink data interface: Integrated RS485 comm card saves over \$200 compared to some competitors

Integrated inverter display: Easy to use push-button interface to configure the inverter and access stored PV system data on the LCD screen

Integrated night switch: Activates inverter display even after the PV system has shut down

blueplanet web: Free monitoring option for residential systems up to 10 kW

Warranty

KACO easySwap policy: No hassle inverter exchange policy is linked to serial number not original owner. No paperwork necessary.

Reimbursement policy: KACO's \$150 warranty service reimbursement is among the best in the industry

KACO guarantee: 02xi series inverter repairs after warranty will never be more than \$500

10 years standard warranty: Warranties are only as valuable as the strength and longevity of the manufacturer. KACO is one of the few established inverter companies older than the warranties they offer.



Model number	blueplanet 1502xi	blueplanet 2502xi	blueplanet 3502xi	blueplanet 5002xi
Input data (DC)				
DC operating range (MPP)	125 – 400 V _{DC}	200 – 450 V _{DC}	200 – 510 V _{DC}	200 – 510 V _{DC}
Max. DC input voltage	550 V _{DC}	550 V _{DC}	600* V _{DC}	600* V _{DC}
Nominal DC input current	14.3 A _{DC}	13.5 A _{DC}	18.5 A _{DC}	26.5 A _{DC}
Max. DC input Isc current	21.45 A _{DC}	21.45 A _{DC}	28 A _{DC}	40 A _{DC}
Output data (AC)				
Max. continuous output power (CEC)	1500 W	2500 W	3500 W	5000 W
Max. over-current protection	15 A	20 A	25 A	30 A
Max. continuous current	240 V	8 A _{AC}	12 A _{AC}	16 A _{AC}
	208 V	8 A _{AC}	12.5 A _{AC}	17 A _{AC}
AC operating range	240 V	211 – 264 V		
	208 V	184 – 226 V		
	220 V	198 – 242 V (for Mexico)		
Frequency	60 Hz (59.3 – 60.5 Hz)			
CEC rated efficiency	240 V	95.5%	95.5%	95.5%
	208 V	95%	95%	95%
Additional data				
AC/DC disconnect ratings	AC: 300 V – 36 A / DC: 600 V – 40 A			
Cooling	True convection - ultimate reliability (5002xi - fan assisted)			
DC reverse polarity protection	Yes			
Ground fault protection	Integrated ground fault detector/interrupter (GFDI)			
Grounding	Field selectable positive or negative ground option			
Visual displays	Backlit LCD w/ convenient night switch & push button controls			
Included accessory interfaces	easyLink RS485 & S0 port			
Ambient temp @ max AC power	-4°F – +104°F (-20°C – + 40°C)		-13°F – +104°F (-25°C – + 40°C)	
Ambient operating temp	-4°F – +140°F (-20°C – + 60°C)		-13°F – +140°F (-25°C – + 60°C)	
Thermal protection	Yes			
Noise emissions	< 35 dB (silent operation) / 5002xi < 45 dB (near silent operation)			
Night power consumption	0.3 W			
Warranty	Standard easySwap 10 years			
Certifications				
Safety compliance	UL 1741, IEEE 1547, NEC, CSA 22.2 No.107.1-01			
Communications compliance	FCC Part 15 Class B			

* - Unit will only feed power if the PV voltage is less than 550Vdc.

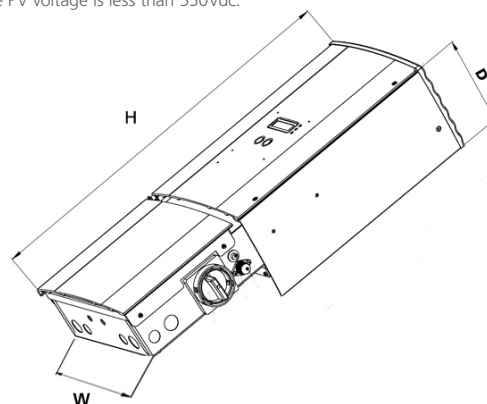

Mechanical Specifications				
Model	Height (H)	Width (W)	Depth (D)	Weight
1502xi	30 in. (761 mm)	14 in. (356 mm)	8 1/4 in. (208 mm)	42 lbs (19 kg)
2502xi	32 in. (813 mm)	14 in. (356 mm)	8 1/4 in. (208 mm)	52 lbs (24 kg)
3502xi	35 7/8 in. (914 mm)	14 in. (356 mm)	9 1/4 in. (241 mm)	69 lbs (31 kg)
5002xi	35 7/8 in. (914 mm)	14 in. (356 mm)	9 1/4 in. (241 mm)	70 lbs (32 kg)
Enclosure	NEMA 3R			

T: +1 (866) 522 6765 • F: +1 (415) 931 1688
kacoinfo@kaco-newenergy.com • www.kaco-newenergy.com

Printed on post consumer material