

SolarMount®/S-5!™ Clamp Sets

Mounting PV Modules to Standing-Seam Metal Roofs

Installation Sheet 220

Thank you for using UniRac products. SolarMount®/S-5!™ clamp sets attach PV modules directly to standing seam metal roofs. No rails or roof penetrations are necessary.

Please review these instructions thoroughly before installing your array.



When an array is attached to a standing-seam metal roof, the roof becomes a structural member of the array. It must be properly secured so that it can support the array under live load conditions, including wind uplift loads. The installer is solely responsible for ensuring that the roof, its rafters or purlins, connections, and other structural support members can withstand design wind forces.

The installer is also solely responsible for:

- Ensuring worker safety on inherently slippery standing-seam metal roofs;
- Complying with all applicable local or national building codes, including any that may supercede this installation sheet;
- Ensuring that UniRac and other products are appropriate for the particular installation and the installation environment;
- Using only UniRac parts and installer-supplied parts as specified by UniRac;

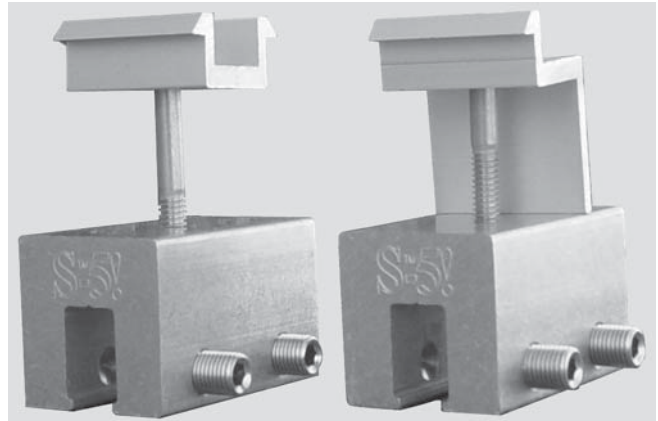

Figure 1. SolarMount/S-5!/mid clamp sets (left) and S-5!/end clamp sets attach PV modules directly to standing-seam metal roofs.

- Maintaining the waterproof integrity of the roof; and
- Ensuring safe installation of all electrical components of the PV array.

Roof seams

The S-5! PV clamp is designed for completely vertical seams only. For standing seam varieties where the S-5! PV clamp is not suitable, please call UniRac for technical assistance with other types of S-5! clamps.

10 year limited Product Warranty, 5 year limited Finish Warranty

UniRac, Inc., warrants to the original purchaser ("Purchaser") of product(s) that it manufactures ("Product") at the original installation site that the Product shall be free from defects in material and workmanship for a period of ten (10) years, except for the anodized finish, which finish shall be free from visible peeling, or cracking or chalking under normal atmospheric conditions for a period of five (5) years, from the earlier of 1) the date the installation of the Product is completed, or 2) 30 days after the purchase of the Product by the original Purchaser ("Finish Warranty").

The Finish Warranty does not apply to any foreign residue deposited on the finish. All installations in corrosive atmospheric conditions are excluded. The Finish Warranty is VOID if

the practices specified by AAMA 609 & 610-02 – "Cleaning and Maintenance for Architecturally Finished Aluminum" (www.aamanet.org) are not followed by Purchaser. This Warranty does not cover damage to the Product that occurs during its shipment, storage, or installation.

This Warranty shall be VOID if installation of the Product is not performed in accordance with UniRac's written installation instructions, or if the Product has been modified, repaired, or reworked in a manner not previously authorized by UniRac IN WRITING, or if the Product is installed in an environment for which it was not designed. UniRac shall not be liable for consequential, contingent or incidental damages arising out of the use of the Product by Purchaser under any circumstances.

If within the specified Warranty periods the Product shall be reasonably proven to be defective, then UniRac shall repair or replace the defective Product, or any part thereof, in UniRac's sole discretion. Such repair or replacement shall completely satisfy and discharge all of UniRac's liability with respect to this limited Warranty. Under no circumstances shall UniRac be liable for special, indirect or consequential damages arising out of or related to use by Purchaser of the Product.

Manufacturers of related items, such as PV modules and flashings, may provide written warranties of their own. UniRac's limited Warranty covers only its Product, and not any related items.

Parts

	Wrench	Recommended torque (ft.-lbs.)
S-5! clamp w/ 2 sets screws	3/16" allen	10–13
SolarMount end clamp w/ hexhead bolt	7/16"	12–15
SolarMount mid clamp w/ hexhead bolt	7/16"	12–15



Stainless steel hardware can seize up, a process called galling. To significantly reduce its likelihood, (1) apply lubricant to bolts, preferably an anti-seize lubricant, available at auto parts stores, (2) shade hardware prior to installation, and (3) avoid spinning on nuts at high speed. See Installation Supplement 910, *Galling and Its Prevention*, at www.unirac.com.

Layout and required attachments

Always mount PV modules in landscape mode. In other words, the long edges of the modules, which will take the clamps, must be perpendicular to the seams of the roof.

An S-5!/end clamp set consists of one S-5! PV clamp with set screws and one SolarMount end clamp with mounting bolt. An S-5!/mid clamp set consists of one S-5! PV clamp with set screws and one SolarMount mid clamp with mounting bolt. Use one clamp set wherever the long edge of a module crosses a standing seam. Even a very small PV module must be secured by no fewer than four attachments.

Assembly

Loosely assemble all clamp sets on the ground. On the roof, follow these steps.

1. On the roof, begin with the lowest row of modules. Use a chalk line or other means to precisely align and mark clamp positions for the bottom edge of the row. Attach and tighten S-5!/end clamp sets to these positions. Tighten the set screw to 10 foot-pounds. Tightening each set screw will affect the other, so retighten both, again to 10 foot-pounds.



Tightening the set screws may tilt the S-5! on the seam. Place and secure modules to bring the clamp back to the proper orientation. For any particular type of seam, use the experience of the first four or five connections to develop your technique.

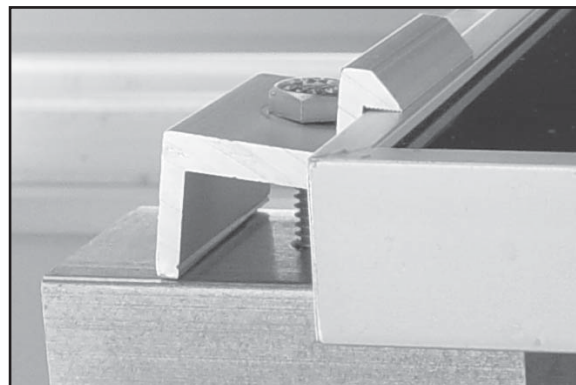

Figure 3. Lean the SolarMount end clamp slightly into the module. Avoid perpendicular orientation and never allow the clamp to lean away from the module.

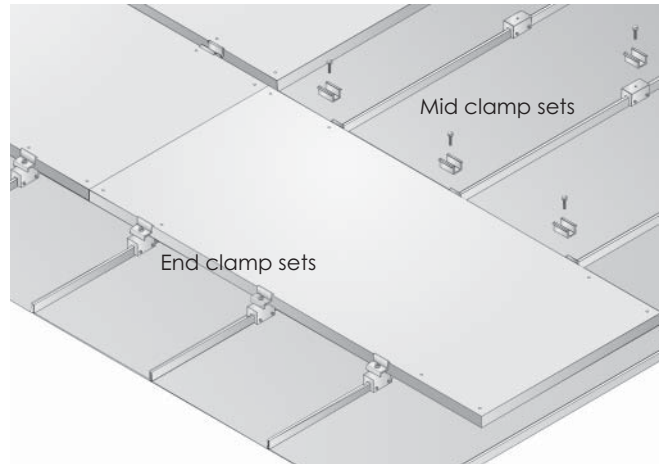

Figure 2. Align and install the lower S-5!/end clamp sets first, followed by the first row of PV modules and the first row of S-5!/mid clamps. Work up the slope of the roof.

2. Position the lowest row of modules and loosely clamp them in place with the SolarMount end clamps. Position the next row of clamp sets to support the upper side of the first row of modules. Use S-5!/mid clamp sets between rows of modules.

Never substitute an S-5!/mid clamp set where an S-5!/end clamp set is required. Use mid clamp sets between modules only.



3. Securely fasten the S-5! PV clamp, while observing the caution in Step 1. Once a module row is supported on both the upper and lower sides, fully torque the hexhead bolts on the SolarMount clamps on the lower set of clamps.

A SolarMount end clamp should lean slightly into the module (Fig. 3).



4. Continue this procedure for each row of modules. For the top edge of the highest row, use S-5!/end clamp sets.