

# Quick Mount PV<sup>®</sup>

Your *Solution* in Mounting Products

Solar • H<sub>2</sub>O • Conduit • HVAC • Custom

## Tile Specifications

All Patents Pending

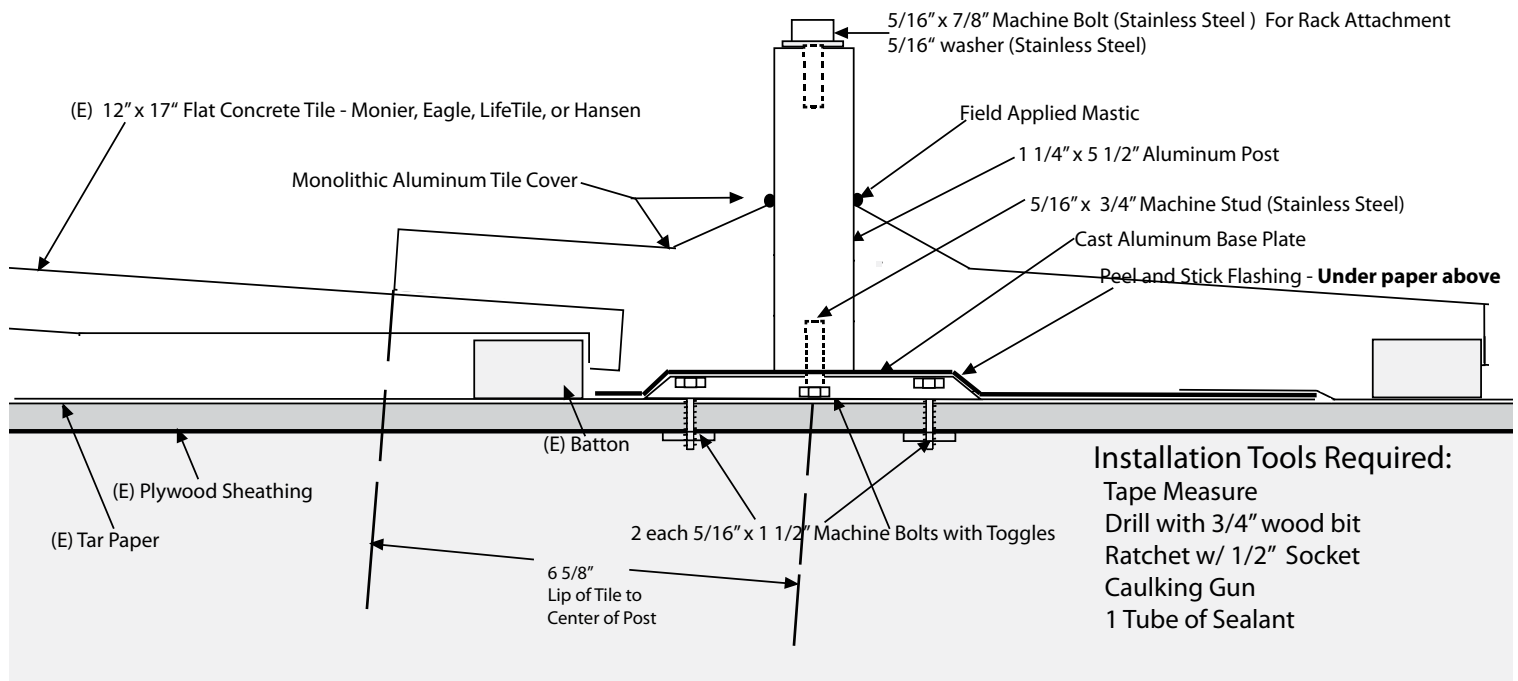

Pull-out (withdrawal) capacities (lbs) in typical lumber:  
machine screw specifications - 5/16" x 1 1/2" (2 each per Mount)  
5/16" Toggle (2 each per Mount)

Minimum repetitive pull out testing exceeded 1000 lbs in each:  
1/2" plywood  
1/2" OSB (oriented strand board)

\* Note: To maintain waterproofing of substrate it is important to make sure the peel and stick flashing is properly placed over the mount base, and under the course of paper above. If the paper above does not reach due to layout, place an additional piece of roofing paper over the peel and stick and under the next course of paper above.

