

INSTALLATION GUIDE

DELTA T PRO
CONTROL UNIT



1. OVERVIEW	2
2. INSTALL & WIRING	3
3. NETWORKING	8
4. SETTINGS	9
5. MONITORING	11
6. TROUBLE	12
7. WARRANTY	14

1. OVERVIEW

1.0. For service, contact Heliodyne: (888)878-8750

1.0.0. Safety Guidelines

This control conforms to the National Electric Code and is certified by the Underwriters Laboratory. **Any electrical wiring or modifications to the control I/O should be performed with the power disconnected.**

Carefully review all instructions in this manual for installation and use. Do not modify equipment under any circumstances; use only as designed. Install all components in an accessible location for servicing and maintenance. Noncompliance with these guidelines will void all warranties.

Follow all local building codes and regulations, as well as these industry accepted guidelines and standards:

- BUILDING** USEC, UBC, UPC, NRCA
- ASHRAE** Solar Energy Equipment
- NFPA 70** National Electric Code

1.0.1. Introduction

The Delta-T Pro controller is designed to control solar thermal collector systems for use in domestic water, heating and commercial systems. This control is not suitable for solar pool heating systems.

Each control contains the user interface software which can be accessed via an internet capable device and web browser. When the device is connected to an internet capable network, the controller can transmit data to the Heliodyne monitoring site for detailed data logging and system tracking. For best results,

Heliodyne recommends consulting an IT professional for connecting to the device and configuring network parameters. An intermediate level of knowledge in IT is required to install this controller.

The controller contains battery-backed SRAM, protecting the system clock, settings and data in case of a power outage. Because the battery is only lightly used during these events, it is not user serviceable and will last the life of the control.

1.0.2. Models

The Delta-T Pro controller is available with either an Ethernet connection or a Wi-Fi signal.

- DLTA 000 001 [Ethernet]
- DLTA 000 002 [Wi-Fi 802.11 b/g]

1.0.3. Computing Requirements

- PC, Mac, PDA or other internet capable device
- Web Browser with JavaScript enabled
- Ad-hoc network capable

1.0.4. Network Requirements for Monitoring Communication

- Always on internet connection (DSL, cable, T1, etc.)
- Available static IP-Address for controller
- Network must allow TCP communication on ports 25 and 9999
- [Wi-Fi] 802.11b/g compatible router with Open, WPA - TKIP, or WPA2 - CCMP (aka AES) encryption

WEP OR OTHER WPA/WPA2 ENCRYPTION ALGORITHMS ARE NOT SUPPORTED

2. INSTALL & WIRING

2.0. Installation

2.0.0. Mounting the Standalone Box

The Delta-T Pro should be mounted on a wall indoors, away from weather and interference. Using the mounting holes on the back of the box, securely install 3 screws into mounting plane leaving 1/4" between the wall and the back of the bolt head; place control back upon screws and slide down to secure box tightly into screw pattern. A separate screw template is provided with this manual.

An ideal installation location is:

- About 5 ft. (1.5m) off the finished floor
- Away from equipment and other sources of electrical interference
- Out of direct sun; in a cool dry location

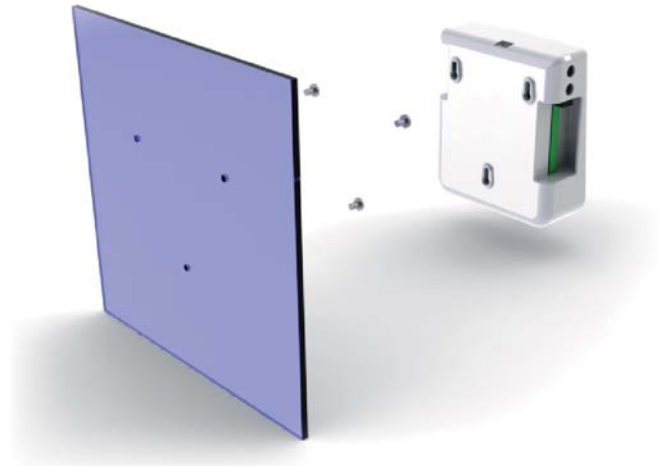

2.1. Controller Inputs and Outputs

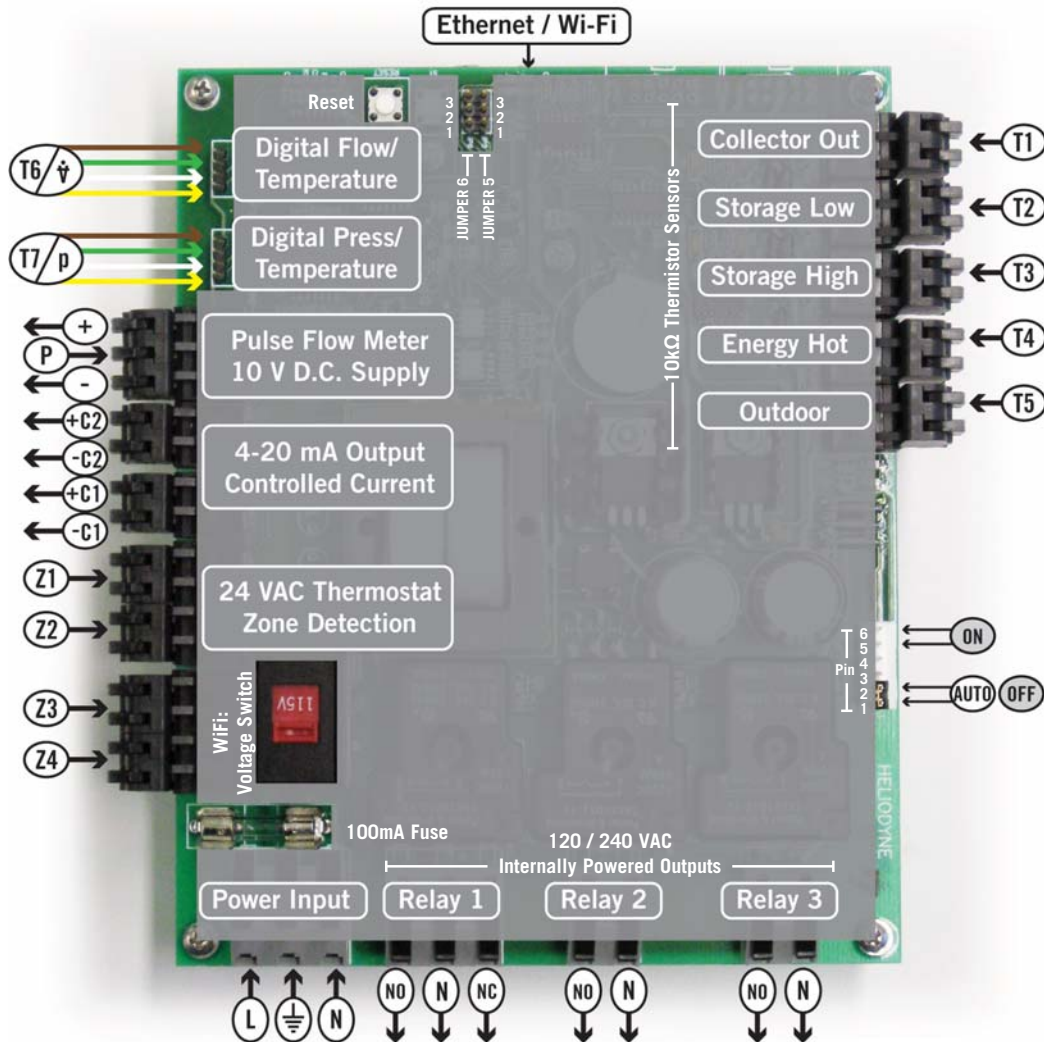

2.2. Wiring

2.2.0. Power Wiring and LED Indication

This control comes pre-wired with a grounded electric cord for plug-in operation in 115VAC systems. If a modification needs to be made to the power connection, connect the appropriate Load, Ground and Neutral wires to the connector.

A red LED will light up when power is applied to the board. Likewise, when the relays have been activated, either by the controller or manually, a Green LED next to the active relay will show.

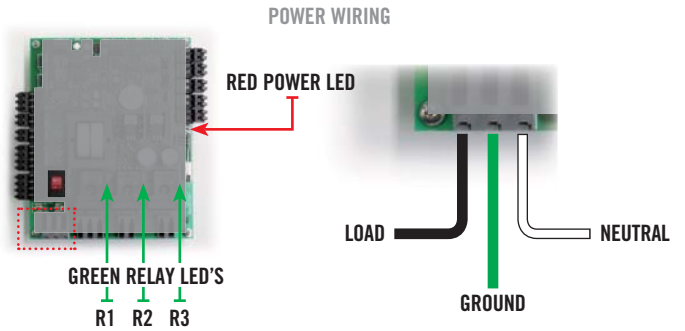

2.2.1. Wi-Fi Models: 230 VAC Switch

Optionally, on Wi-Fi controllers, the voltage switch can be adjusted to handle 230VAC supply (modification of the cord plug may be necessary). Use caution as this also changes the supply voltage to the relays. I.E. if the switch is set to 230VAC supply, the pumps or accessories wired to the relays must also be able to operate on 230VAC. Heliodyne packaged units come default with 115 VAC pumps, unless specifically ordered otherwise.

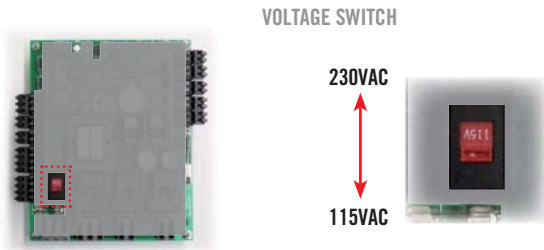

2.2.2. Relay 1 Wiring and Functionality

Relay 1 has a N.O. and N.C. connection; they share a common middle neutral connection. For components with a ground wire, a connection can be made using the power's ground wire.

- N.O. - Solar Relay: this is the connection for the solar operation pumps. Both the solar and the tank pumps in dual pumped systems are connected here.
- N.C.: this connection can be used to power components that operate opposite to the solar operation, such as a pool controller with domestic water heating priority

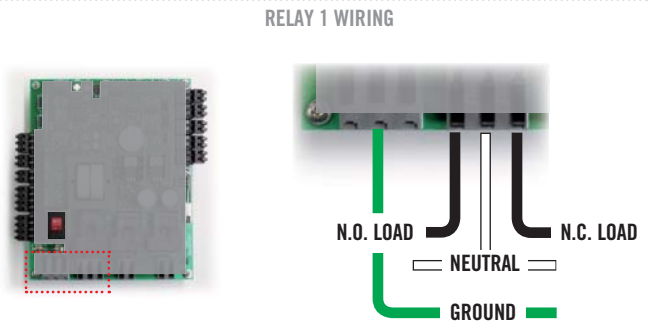

2.2.3. Relay 2 Wiring and Functionality

Relay 2 has only a N.O. connection. For components with a ground wire, a connection can be made using the power's ground wire. Relay 2 can have one of two potential uses, depending on the operating mode (see SETTINGS for more information on operating modes)

- Space Heating Mode: Relay 2 can operate a pump or valve when a thermostat terminal is closed and the set temperature is reached in the tank sensor (T2 or T3 if installed)
- Commercial Mode: In dual pumped systems with variable speed pumps, the control can operate Relay 2 to power the domestic water circulator independently of the solar loop circulator.

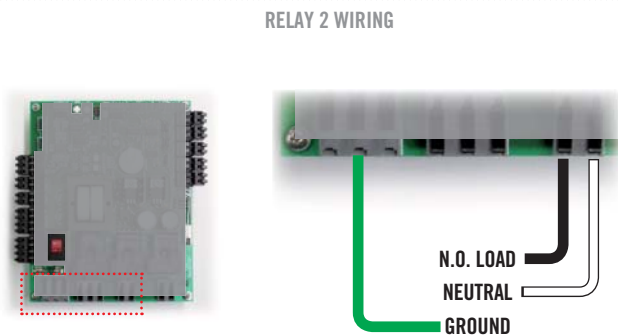

2.2.4. Relay 3 Wiring and Functionality

Relay 3 has only a N.O. connection. For components with a ground wire, a connection can be made using the power's ground wire. Relay 3 can have one of three potential uses.

- Electric Ignition Gas Tank Operation: Connect the tank power cord to this relay.
- Timer Operation: Turn this relay on and off at a set hour during each day.
- Extraneous Operation: Operate this relay when T2 reaches a user set temperature.

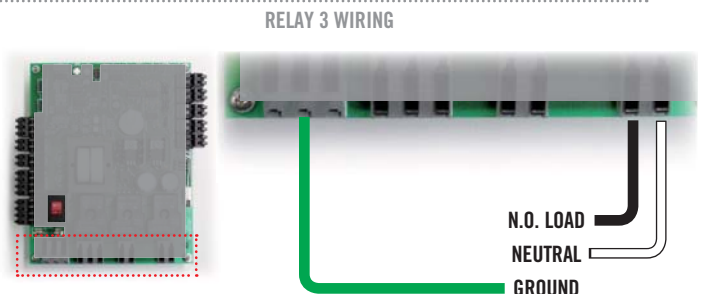

2.2.5. Relay Specification Summary Table

ITEM	RELAY 1	RELAY 2	RELAY 3
Contact Voltage (Wetted)	115 or 230	115 or 230	115 or 230
Contact Type	N.O. & N.C.	N.O.	N.O.
Ratings	20A, 240VAC [N.O.] 10A, 240VAC [N.C.]	30A, 240VAC	30A, 240VAC

2.3. Sensors

2.3.0. Types

The Delta-T Pro can read two types of sensors: 10kΩ Thermistors and Grundfos VFS (Vortex Flow Sensor) and RPS (Relative Pressure Sensor) sensors.

2.3.1. Thermistor Sensors

We have two mounting styles of thermistors available, each suitable for different system placement:

- SENS 000 001: The flattened copper lug can be attached to the sensor stud on a solar storage tank, or can be strapped to the outside of the system fluid tubing.
- SENS 001 001: The sensor works in conjunction with the immersion well, and can be placed in the fluid stream for greater accuracy.



The sensor leads are 24AWG Class II and carry 4VDC. Use 18-24AWG zip or bell wire to run from the sensor location to the controller. Use caution when installing to avoid wire damage. Shielded wire is not necessary. Use insulation and weatherproofing for accurate sensor readings. Install out of direct sunlight.

2.3.2. Grundfos Sensors

Heliodyne recommends Grundfos VFS sensors for flow measurement. Because of the vortex principle, they are less expensive, last longer, and more accurate than pulse / paddle-wheel sensors. They also combine a temperature measurement. Model selection is based on design flow rate; we have 4 flow sizes and 1 pressure size:

- FLOS 010 000 [to 10.5 GPM]
- FLOS 026 000 [to 26 GPM]
- FLOS 053 000 [to 53 GPM]
- FLOS 106 000 [to 106 GPM]
- PRSS 150 000 [to 150 psi]

SENSOR INSTALLATION

THERMISTOR SENSORS

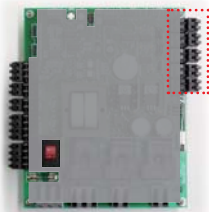

GRUNDFOS SENSORS

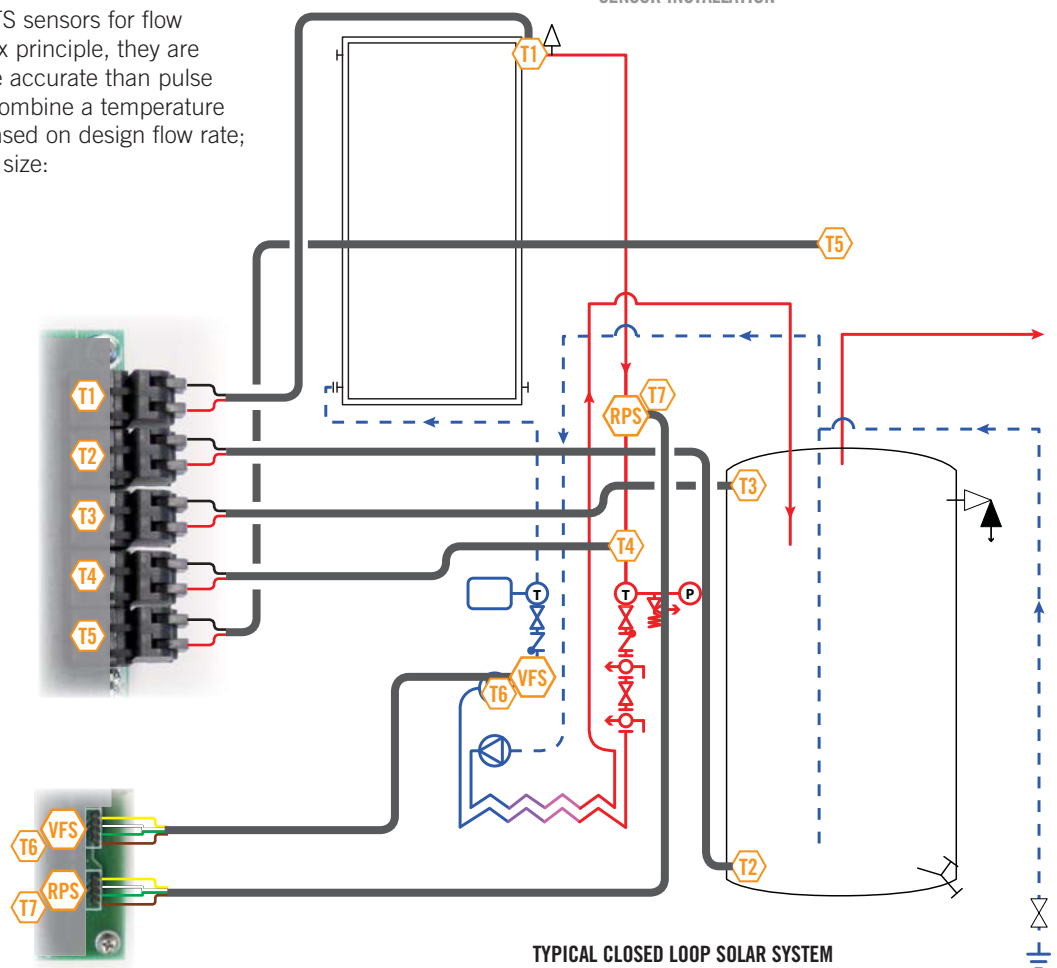
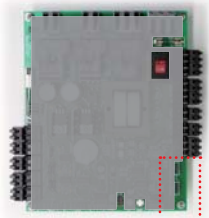

2.3.3. Collector Sensor T1

Supplied with HPAK, HCOM, and HFLO systems

TYPE: 10kΩ Thermistor

USE: REQUIRED

FUNCTIONS:

- 'Hot' differential operation
- 'Hot' energy calculation
- Freeze monitoring sensor for open loop
- Low temperature monitor for vacation mode
- Useful collector temperature monitor
- Drain back system high limit monitor

WARNINGS:

- Isolate from ambient
- Never install inside collector
- Install on collector outlet header only

2.3.4. Low Tank Sensor T2

Supplied with HPAK, HCOM, and HFLO systems

TYPE: 10kΩ Thermistor

USE: REQUIRED

FUNCTIONS:

- 'Cold' differential operation
- Tank high limit monitor
- Low temperature monitor for vacation mode
- Single Tank Gas function monitor
- Relay 2 space heating setpoint
- Relay 3 operation setpoint

WARNINGS:

- Isolate from ambient
- Ensure contact with tank wall

2.3.5. High Tank Sensor T3

TYPE: 10kΩ Thermistor

USE: OPTIONAL

FUNCTIONS:

- 'Cold' differential operation average with T2
- Tank high limit monitor average with T2
- Low temperature monitor for vacation mode average with T2
- Single Tank Gas function monitor average with T2
- Relay 2 space heating setpoint in place of T2
- Relay 3 operation setpoint in place of T2

WARNINGS:

- Isolate from ambient
- Ensure contact with tank wall

2.3.6. Heat Exchanger Inlet T4

TYPE: 10kΩ Thermistor

USE: OPTIONAL

FUNCTIONS:

- 'Hot' energy calculation in place of T1

WARNINGS:

- Isolate from ambient
- Ensure contact with measuring surface or use immersion sensor

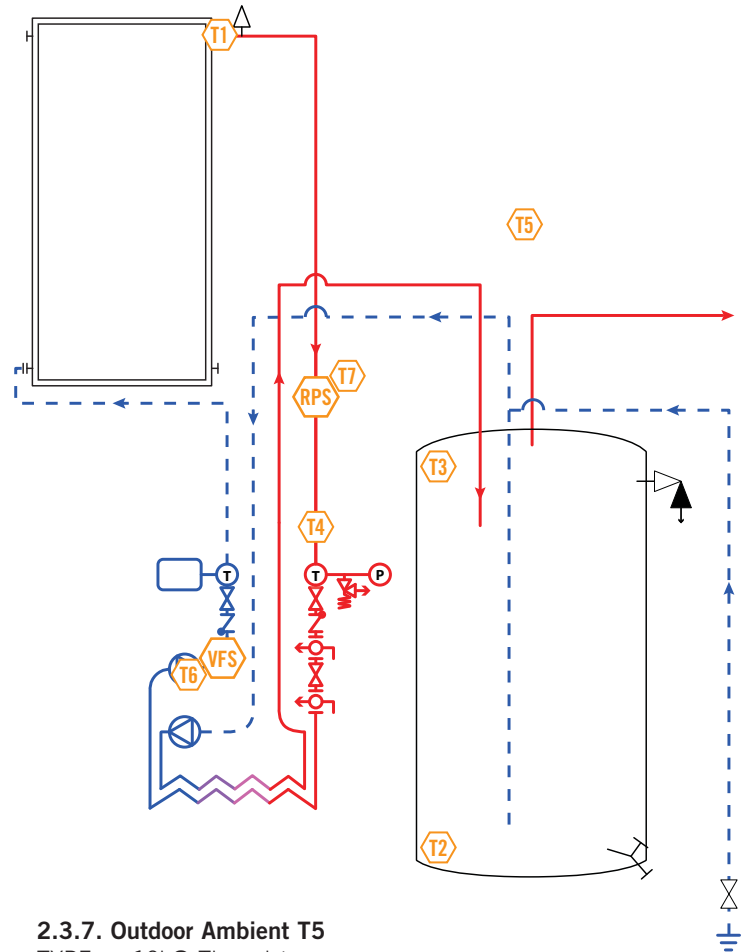

2.3.7. Outdoor Ambient T5

TYPE: 10kΩ Thermistor

USE: OPTIONAL

FUNCTIONS:

- Outdoor monitoring
- Outdoor reset in space heating mode

WARNINGS:

- Keep out of direct sunlight

2.3.8. Grundfos VFS and T6

Supplied with Pro Series and HCOM

TYPE: Vortex Flow Sensor

USE: OPTIONAL

INFO: Can be moved to measure flow anywhere in the solar system and calculate energy at that point, provided T4 is installed downstream at the 'Hot' location for temperature difference.

FUNCTIONS:

- Monitor flow rate for energy calculation
- 'Cold' energy calculation

WARNINGS:

- Ensure correct VFS range is set in settings

2.3.9. Grundfos RPS and T7

TYPE: Relative Pressure Sensor

USE: OPTIONAL

FUNCTIONS:

- Solar system pressure monitoring

WARNINGS:

- N/A

2.4. Additional Functions

2.4.0. Functions

The Delta-T Pro controllers can be wired to access several additional functions as described below. Control reset and manual operation of the relays is also addressed here.

2.4.1. Thermostat Zone Detection

Household thermostats can be wired into 1 of the 4 spots on the controller for detection upon close indicating a call for heat. There is one pluggable insert for two connection pairs.

The contacts are not wetted and need to be supplied 24VAC to detect a call for heat. Relay 2 will be operated if a zone calls for heat and the temperature read on either T2 or T3 (if installed) is above the set temperature in the settings.

ZONE DETECTION WIRING

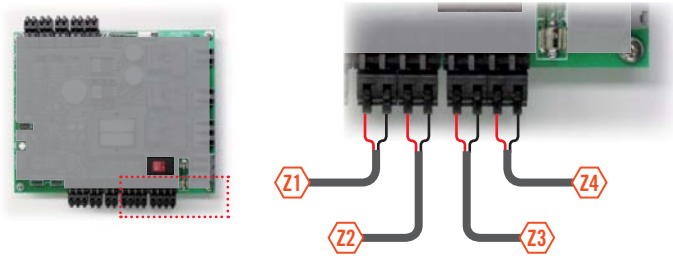

2.4.2. Variable Speed Current Output

A 4-20mA controlled current output is supplied to pumps for variable speed operation when selected in the settings. The principle of operation is to keep the temperature gain across the collectors constant throughout the day and between 8°F and 15°F. If there is not sufficient solar energy to collect, the pumps operate at a minimum speed (provided a satisfactory differential). If there is ample solar energy, the pumps operate at maximum speed. Take care to preserve polarity. Wire the appropriate supply to the pump's AC input and use Relay 1.

CONTROLLED CURRENT WIRING

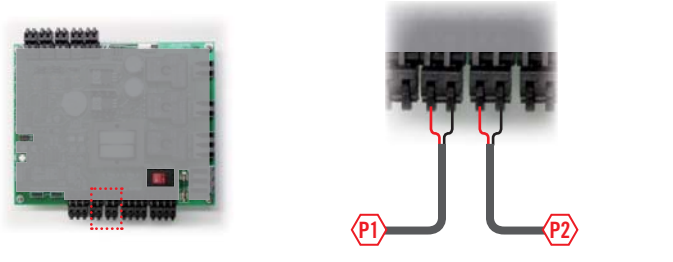

2.4.3. Pulse Flow Meter Connection

If necessary, a pulse flow meters can be used in place of the use of a Grundfos VFS. The meter must be capable of producing a pulse with a pull up to positive DC voltage of 3VDC. The controller provides 10VDC supply to the meter. Ensure the number of pulses are set in the settings.

PULSE FLOW METER WIRING

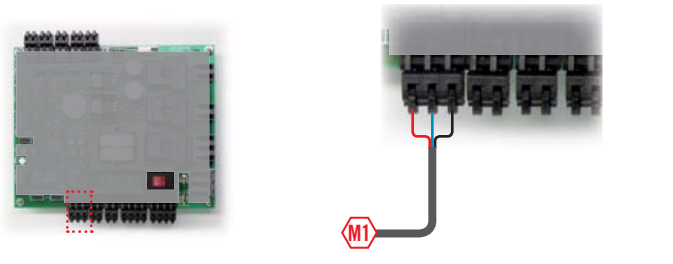

2.4.4. Manual Operation of Relays

Often it is necessary to test the relays manually, or shut off the relays should a problem occur. The current version of the Delta-T Pro offers a set of 6 pins for which to provide this functionality. The possible modes are OFF, ON, and AUTO. The controller is shipped in AUTO mode, with a removable jumper in the AUTO position. Turning the pumps on requires an additional jumper; use the reset jumper at the left of the board.

MANUAL RELAY OPERATION

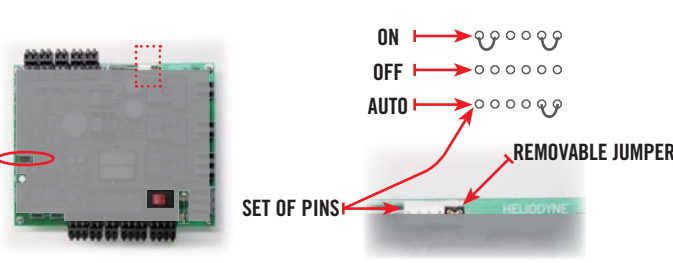

This part of the board is low voltage (<5VDC).

2.4.5. Manual Reset of Network Parameters

To reset the network parameters, place the removable jumper stored at the left and middle pins of the JP5 location on the left of the board, to the middle and right pins. With the jumper in place, firmly press the reset button and hold for approximately two seconds. Replace the jumper in its original location.

NETWORK RESET

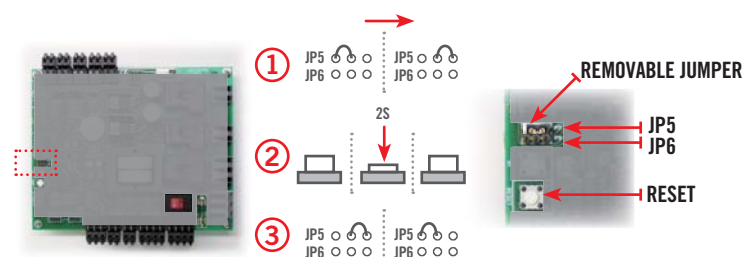

3. NETWORKING

3.0. Network Overview

The Heliodyne controllers use internet protocol (IP) to display information on a web page. They use two types of physical connection for communication with devices:

- Ethernet [Cat 5 cable connection - DLT A 000 001]
- Wi-Fi [802.11 b/g wireless signal - DLT A 000 002]

The controllers use Ad-Hoc networking, or computer to computer direct connect, for initial controller setup and operational use. The Pro can optionally be installed on a local area network, or Infrastructure, for ease of viewing data and communication with the Heliodyne Monitoring Servers.

To begin the configuration setup of the Delta-T Pro, supply the unit with power, and prepare the computer, PDA or device for connection with the controller's default ad-hoc network:

- Disconnect from any other Ethernet, WiFi, modem, or network connection.
- For laptops connecting to Ethernet controls, ensure the power cable is connected as many computers disable the Ethernet port to conserve battery power.
- For Windows Vista users, enable file sharing.

3.1. Connect to the Controller

The Pro has the following default network parameters:

IP Address: 169 . 254 . 148 . 50
 Subnet Mask: 255 . 255 . 0 . 0
 Gateway: 169 . 254 . 148 . 1

3.1.0. Connecting to DLT A 000 001 [Ethernet]

1. Connect a Cat 5 Ethernet cable to the Ethernet port on the computing device. (Crossover not required)
2. Wait for the computer to resolve the IP address (up to 30 seconds depending on computer speed)
3. Open a new web browser window.
4. Enter the controllers web address into the web browser: 169.254.148.50

3.1.1. Connecting to DLT A 000 002 [Wi-Fi]

1. Search for the controller's default Wi-Fi network name (SSID): "DTT PRO WIFI" and connect to it.
2. Wait for the computer to resolve the IP address (up to 30 seconds depending on computer speed).
3. Open a new web browser window.
4. Enter the controller's web address into the web browser: 169.254.148.50

3.1.2. Web Interface Home Page Overview

1. Web browser
2. Software Version
3. Controller IP Address
4. Navigation Bar
5. System Schematic
6. System Time and Date
7. Sensor Readings (Shown if installed)
8. Relay Status

The SETTINGS parameters are password protected. For first time editing, enter the CASE SENSITIVE defaults when prompted:

User name: **Admin**
 Password: **caution**

The password can be and is recommended to be changed once inside the settings on the first tab, System. If a password is lost or forgotten, it can be reset to the default by following the steps in section 2.4.5.

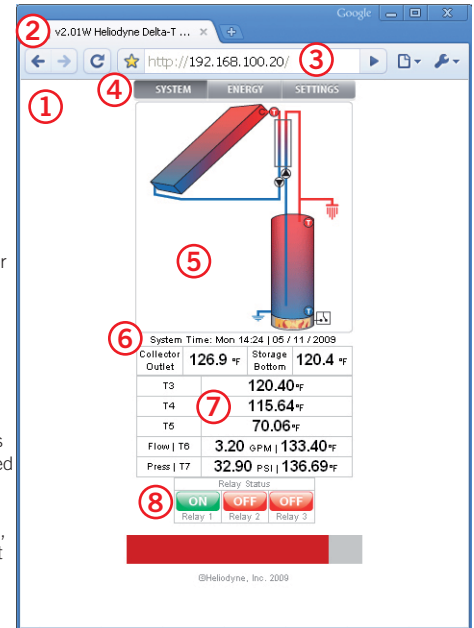

3.2. Infrastructure Mode

Before placing the control on an Infrastructure, consult a network administrator, or an IT professional to get the appropriate settings and information for the local area network (LAN).

3.2.0. DLT A 000 001 [Ethernet]

1. Bring up the controller's web interface as in section 3.1.
2. Navigate to the SETTINGS screen, and then to the Network tab.
3. Enter in the available static IP address for the controller.
4. Enter in the LAN's Subnet Mask
5. Enter in the LAN Gateway (often this is also referred to as the Router).
6. Save the new settings.

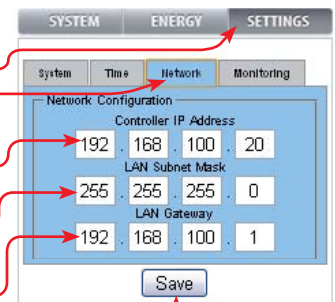

Provided the correct parameters were set, the controller will now be available through your LAN at the IP Address saved in the controller. It will no longer be available at the default address. If the controller's network settings need to be reset, follow the instructions in section 2.4.5.

3.2.1. DLTA 000 002 [Wi-Fi]

1. Bring up the controller's web interface as in section 3.1.
2. Navigate to the SETTINGS screen, and then to the Network tab.
3. Set Infrastructure Mode Active.
4. Enter in the available static IP address for the controller.
5. Enter in the LAN's Subnet Mask.
6. Enter in the LAN Gateway (often this is also referred to as the Router).
7. Select Encryption (review compatibility requirements in 1.0.4).
8. Enter the Wi-Fi network for the controller to associate with.
9. Enter the network password if not Open.
10. Save the new settings.

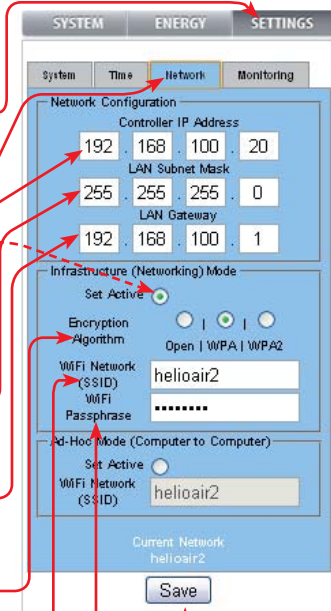

Provided the correct parameters were set, the controller will now be available through your LAN at the IP Address saved in the controller. The control will no longer be available at the default address. If using a password protected network, the controller will take approximately 30 seconds to hash the hex key for use with authentication; the Pro will be non-responsive during this time.

If the network settings fail, the control will reset itself within one minute's time to transmit again in Ad-Hoc mode with the default SSID and network settings.

3.2.1. Wi-Fi Ad-Hoc Mode

- To change back to Wi-Fi Ad-Hoc mode, Set Active in the SETTINGS > Network tab.
- The network parameters are reset to the defaults and cannot be changed in this mode, except for the SSID.
- The Wi-Fi Ad-Hoc SSID can be renamed.
- Save the settings to take effect.

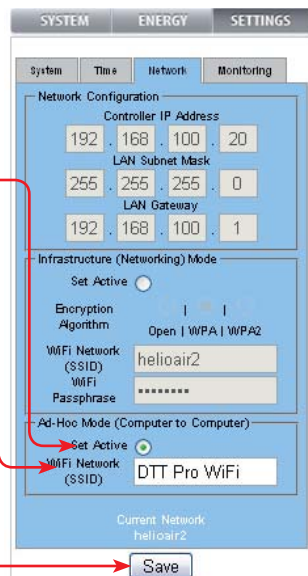

4. SETTINGS

4.0. Quick Start

For fast setup, here is a list of parameters that may need to be adjusted to properly control simple DHW systems. Remember to save any adjusted settings.

1. Adjust the system clock to reflect the local time.
2. If using an open loop system, change the system type to Open Loop for enabling freeze protection.
3. If using a Grundfos VFS other than installed in an HPAK, HFL0 or HCOM, adjust the flow range to match the sensor installed.
4. If using a gas tank as the solar storage with electric ignition, enable the Gas Tank Operation checkbox.
5. If using a drain back system, enable the Drain Back Operation checkbox.

4.1. SETTINGS Screens and Their Parameters

4.1.0. System Tab

System

- Open Loop Residential DHW**
 - Presets Differentials: On at 9°F and Off at 4°F
 - Enables freeze recirculation at 35°F
 - Adjusts Glycol Concentration to 0%
- Closed Loop Residential DHW**
 - Presets Differentials: On at 18°F and Off at 5°F
 - Disables freeze recirculation
 - Adjusts Glycol Concentration to 50%
- Closed Loop Commercial**
 - Same as Closed Loop Residential +
 - Enables variable speed pumping
- Closed Loop Combination**
 - Same as Closed Loop Residential +
 - Enables Relay 2 operation with zone thermostat detection

Password

- Edit Password**
 - Sets the password for accessing all SETTINGS information.
 - Takes effect after a power cycle, i.e. after the controller has been turned off and on again, or reset.

Advanced Settings

- **Save**: Save. All changes must be saved.
- **Update Software Version**: Link to the software update page.
- **Download System Energy**: Link to download an ANSI text file (.txt) containing the controller's performance data
- **Version: 2.01W**: Delta-T Pro software version. Reference this number when troubleshooting with Heliodyne
- **Mac Address: 00:90:c2:d8:10:c9**: MAC address for the controller
- **Update Software Version**: Link to the Advanced Settings such as Differential and High Limit.

4.1.1. Time Tab

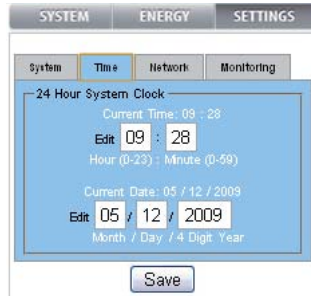

24 Hour System Clock

The Delta-T Pro has a real time clock that is preserved even in a power outage. The clock does not show AM or PM, but rather in the 24-hour format, i.e. 13 is 1 PM.

The real time clock is used for data time-stamping, as well as in certain functions. Always set the time clock to the current local time for best results.

The clock is not automatically adjusted for daylight savings.

4.1.2. Network Tab - See section 3.2.

4.1.3. Monitoring Tab - See section 5.2.

4.2. Advanced Settings

The advanced settings can be accessed via the link on the SETTINGS > System Tab.

4.2.0. Meter Tab

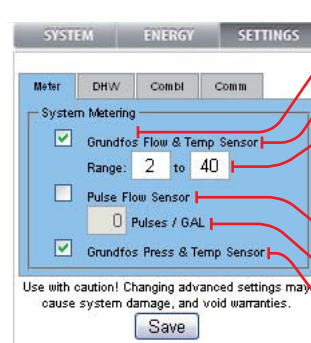

System Metering

Grundfos Flow & Temp Sensor

- Default is enabled
 - Monitors Grundfos VFS
- Range**
- Flow range for VFS installed in LPM
 - Default is 2 - 40 as installed in HPAK, HFLO models (HCOM models are also preset with model specific VFS)
 - If installing standalone VFS, locate the range on the invoice or packing slip.

Pulse Flow Sensor

- Check to enable monitoring of this type of sensor
- Adjust the Pulses / Gal to get an accurate reading

Grundfos Press & Temp Sensor

- Enable to monitor the Grundfos RPS

4.2.1. DHW (Domestic Hot Water) Tab

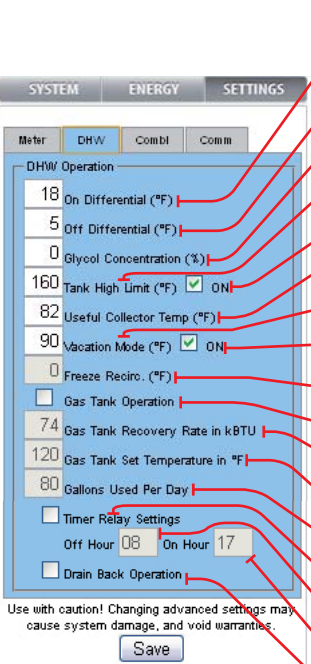

FUNCTION DESCRIPTION	DEFAULT	SETTING LIMIT
The Value T1 must be greater than T2 by, or the average of T2 & T3 if installed, in order for Relay 1 to turn ON	18°F [CL], 9 [OL]	5°F ≤ V ≤ 50°F
If R1 is ON, the sum of this Value and T2 – or the average of T2 & T3 if installed – that T1 must be less than in order for R1 to turn OFF	5°F [CL], 4 [OL]	3°F ≤ V < On Diff.
The percentage of Dowfrost HD propylene glycol in the heat transfer fluid to be used in the energy calculation	50% [CL], 0 [OL]	0% ≤ V ≤ 70%
The limit Value T2, or the average of T2 & T3 if installed, at which the solar relay will turn OFF even with a satisfactory differential. NOT TO BE RELIED UPON AS A SAFETY LIMIT OR PRIMARY LIMIT CONTROL.	160°F	80°F ≤ V ≤ 200°F
Check this box to use the Tank High Limit Function	ON	ON / OFF
The minimum Value T1 must be greater than for the differential function to begin monitoring the differential	82°F [CL], 80 [OL]	50°F ≤ V ≤ 100°F
Uses the cool nighttime collectors to deplete energy from the storage. Set the minimum T2 Value, or T3 if installed, to cool the tank down to.	120°F	80°F ≤ V ≤ 180°F
Check this box to use the Vacation Mode function	OFF	ON / OFF
If the selected system on the SETTINGS > System tab is Open Loop, recirculates warm storage water through the collector loop when this value is greater than T1.	35°F [OL Only]	33°F ≤ V ≤ 50°F
Check this box if using a electric ignition gas fired solar storage tank systems (EIGFSS), with power controlled by R3.	OFF	ON / OFF
In EIGFSS tank systems, the tank's rated recovery rate in kBTU (1000 x BTU)	74kBTU	30kBTU ≤ V ≤ 120
In EIGFSS tank systems, the limit Value at which T2, or T3 if installed, will disable R3, preventing any backup energy	120°F	80°F ≤ V ≤ 140°F
In EIGFSS tank systems, the estimated household demand in gallons used per day	80°F	40°F ≤ V ≤ 140°F
Check this box if using R3 as a timer relay. Relay capacity is 30A, 240VAC.	OFF	ON / OFF
At the top of this hour Value, i.e. 8:00 or 8 AM, R3 will shut OFF. The clock is a 24-hour clock.	8:00	0 ≤ V ≤ 23
At the top of this hour Value, i.e. 17:00 or 5 PM, R3 will turn ON. The clock is a 24-hour clock.	17:00	0 ≤ V ≤ 23
Check this box to use the Drain Back Operation limit function, which limits R1 from operating if the current differential is greater than (T12 - Tank High Limit)	OFF	ON / OFF

4.2.3. Combi (Combination System) Tab

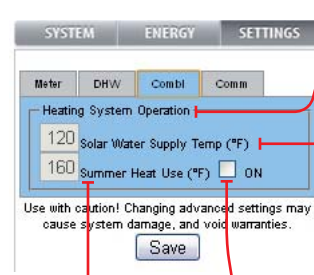

Heating System Operation

Solar Water Supply Temp

- Enabled when Closed Loop Combination system is selected in SETTINGS > System
- Monitors the Thermostat Zone Detection Inputs for a call for heat
- Checks the temperature of T2 or T3 if installed.
- Range of Value: 80°F ≤ V ≤ 200°F
- Turns R2 ON when **(Value + 5) < (T2 or T3) AND There is a call for heat**
- Turns R2 back OFF when **(Value - 5) > (T2 or T3) OR There is no call for heat**

Summer Heat Use

- Enabled when the box next to the description is checked, REGARDLESS OF SYSTEM SELECTED
- Monitors the temperature of T2 or T3 if installed.
- Range of Value: 80°F ≤ V ≤ 200°F
- Turns R3 ON when **(Value + 5) < (T2 or T3)**
- Turns R3 back OFF when **(Value - 5) > (T2 or T3)**

4.2.4. Comm (Commercial System) Tab

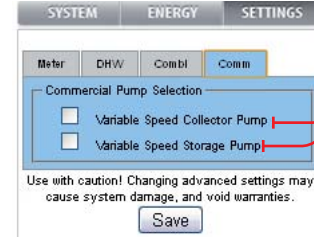

Commercial Pump Selection

Variable Speed Collector / Storage Pump

- Enabled on HCOM systems.
- Enabled when Closed Loop Commercial system is selected in SETTINGS > System
- Outputs a 4-20mA controlled current for use with a pump's speed or frequency drive - not standard on most pumps
- Keeps temperature gain across the collector in the 8 - 20°F range for optimal energy collection
- Optimizes pump energy use by lowering speed when insolation is lower
- Prevents stopping and starting and wearing out relays

5. MONITORING

5.0. Overview

The Controller has two types of monitoring, the built in or Local Monitoring that is stored in the controller's memory, and the Heliodyne Web Monitoring service. The Local Monitoring is limited because of the size of the controller's memory, still it is sufficient to give an overview of the system performance; and it stores the running numbers that are of interest.

When the controller is connected to a network with an internet connection, it communicates with the Web Monitoring service, which is available for viewing performance data and settings from the WWW; anywhere in the world. It is also possible to change settings, add site pictures and more. Contact Heliodyne for further information and information on obtaining a login.

5.1. Local Monitoring

5.1.0. Energy Tab

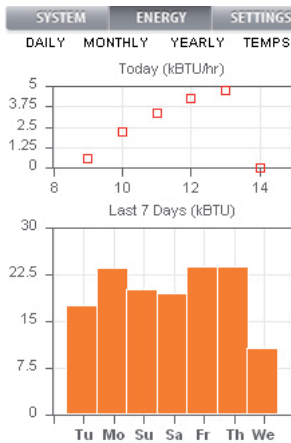

- DAILY**
 - Today (kBTU / hr)**
 - Displays the average energy rate in kBTU / hour for the current day's production
 - Last 7 Days (kBTU)**
 - Displays the past seven days of energy production in kBTU
- MONTHLY**
 - Displays the past 12 months of energy production in MBTU
- YEARLY**
 - Displays the past 5 years of energy production in MBTU
 - Displays the total energy production as a decimal
 - Displays the total CO₂ saved in lbs.
- TEMPS**
 - Displays the connected temperature sensors in bar graph format, in both °F and °C

5.1.1. Local Monitoring Values

On the SETTINGS > System tab, the local monitoring values can be downloaded as a text file. Right click on the link and select 'Save As'. Name the file as you wish. To import it into Excel, open the file and when it prompts for the data separation character, check the 'Comma' box.

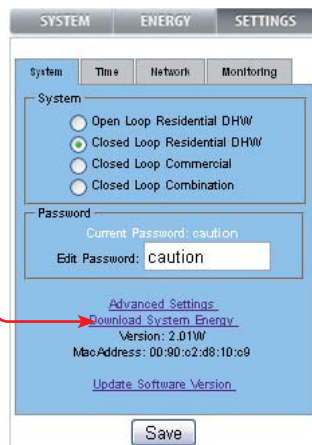

5.2. Monitoring Initial Setup

After the control has been successfully installed on the local network, one last step must be completed in order to get the Monitoring servers to allow communication with the controller. Navigate to SETTINGS > Monitoring to access the settings.

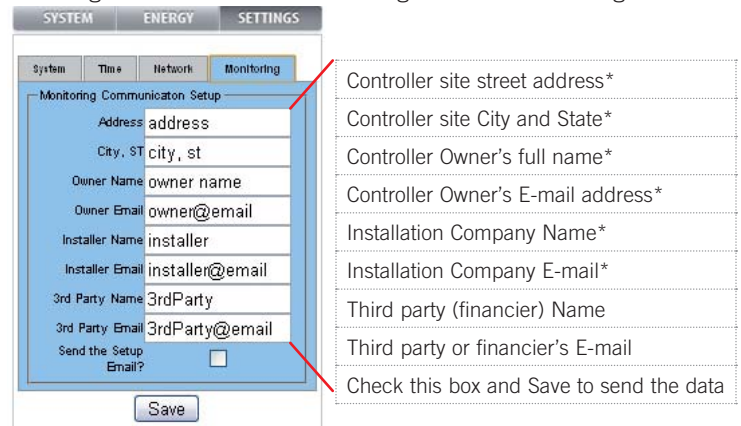

* = Required, control setup will not complete without these values

5.2.0. Monitoring Next Steps

After the setup e-mail is sent, web server accounts will be created and e-mailed to the appropriate addresses usually within 1-2 business days.

After receiving the login information,

- go to <http://monitoring.heliodyne.com>
- Enter your login information on the screen.
- For a tutorial on how to use the Web Service, review the training material on heliodyne.com.

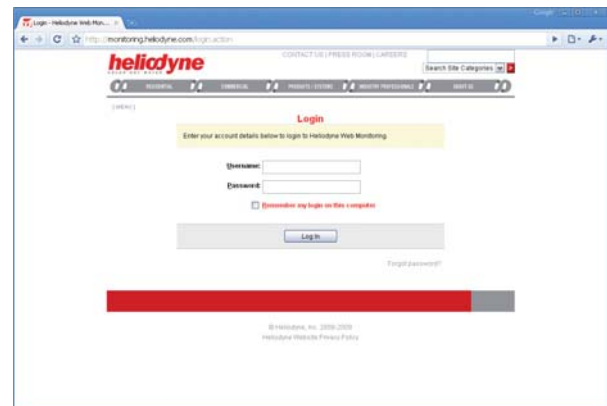

6. TROUBLE

6.0. Delta-T Pro Testing and Troubleshooting

Before contacting Heliodyne tech support, run through this entire section to see if it solves the problem. If the issue cannot be resolved by these tests and common problems, their answers will give Heliodyne a better idea of what the issue might be.

6.0.0. Testing

TEST NAME	METHOD	OUTCOME																																										
Power Test	Supply the controller with power	If there is a red LED near the thermistor sensor inputs, the control has power. If there is no red LED, check the fuse for continuity. If the fuse is bad, replace with a similar 100mA fuse.																																										
On / Off Test	Manually turn the relays on or off	Review section 2.4.4. Turn the relays on; each relay should have a green LED lit up next to it. When lit, test the voltage at the NO contact to see if 120VAC (or 240VAC if switched) is supplied. Turn the relays off; no green LEDs next to the relays should be lit. Test the NO contacts to be sure there is no voltage supplied when off																																										
Basic Sensor Test	Short or Open sensors	A sensor short signals to the controller a high temperature of around 350°F, an open signals a very low temperature of around -90°F.																																										
Sensor Operational Test	Measure the sensor resistance	<p>Disconnect the sensor from the control to prevent any controller feedback. Using a voltmeter set to read Ω, or Ohms, measure the resistance of the installed sensor. Check this table to see if the measured values correspond to the expected values. Bad values can mean the connecting wires or the sensor itself. If a bad sensor is suspected, check the sensor at the 6" factory leads.</p> <table border="1"> <thead> <tr> <th>$^{\circ}\text{C}$</th> <th>$^{\circ}\text{F}$</th> <th>Ω</th> </tr> </thead> <tbody> <tr> <td colspan="2">OPEN</td> <td>Infinity</td> </tr> <tr> <td>0</td> <td>32</td> <td>32,630</td> </tr> <tr> <td>10</td> <td>50</td> <td>19,890</td> </tr> <tr> <td>20</td> <td>68</td> <td>12,490</td> </tr> <tr> <td>25</td> <td>77</td> <td>10,000</td> </tr> <tr> <td>30</td> <td>86</td> <td>8,057</td> </tr> </tbody> </table> <table border="1"> <tbody> <tr> <td>40</td> <td>104</td> <td>5,326</td> </tr> <tr> <td>50</td> <td>122</td> <td>3,601</td> </tr> <tr> <td>60</td> <td>140</td> <td>2,487</td> </tr> <tr> <td>70</td> <td>158</td> <td>1,751</td> </tr> <tr> <td>80</td> <td>176</td> <td>1,255</td> </tr> <tr> <td>100</td> <td>212</td> <td>680</td> </tr> <tr> <td colspan="2">SHORT</td> <td>0</td> </tr> </tbody> </table>	$^{\circ}\text{C}$	$^{\circ}\text{F}$	Ω	OPEN		Infinity	0	32	32,630	10	50	19,890	20	68	12,490	25	77	10,000	30	86	8,057	40	104	5,326	50	122	3,601	60	140	2,487	70	158	1,751	80	176	1,255	100	212	680	SHORT		0
$^{\circ}\text{C}$	$^{\circ}\text{F}$	Ω																																										
OPEN		Infinity																																										
0	32	32,630																																										
10	50	19,890																																										
20	68	12,490																																										
25	77	10,000																																										
30	86	8,057																																										
40	104	5,326																																										
50	122	3,601																																										
60	140	2,487																																										
70	158	1,751																																										
80	176	1,255																																										
100	212	680																																										
SHORT		0																																										
Basic Function Test	Short or Open sensors (assuming no high limit or other extreme conditions)	Test the differential setting & collector: short T1; the pumps should turn on Test the differential setting & storage: open T2 & T2 when T1 is above the Usable Collector Temperature set in the SETTINGS; the pumps should turn on Test the freeze protection in open loop mode: open T1, the pumps should turn on																																										

6.0.1. Troubleshooting Network Issues

ISSUE	POSSIBLE CAUSE	SOLUTION
<ul style="list-style-type: none"> [Wi-Fi] Can't connect to the controller 	Connected to another Wi-Fi or Ethernet network	When the controller is in Ad-Hoc mode, as shipped from the factory, to connect to the "DTT PRO WIFI" network, the computing device cannot be connected to any other network. The device must connect only to the controller's network.
	PC: Computing device driver issue	The best way to connect to a Wi-Fi controller is to use the Operating System's (I.E. Vista, or XP's) connection feature, rather than the device's Wi-Fi card driver software (usually done in the task bar). To connect via the OS, go: Start > Control Panel > Network Connections > Local Area Network and select the network to connect to.
	Computing device has not had time to resolve the IP addresses	Depending on the speed of the device, it can take up to 1 minute for the device to allow communication to the Pro. Close any open browser windows, and reopen once connected.
<ul style="list-style-type: none"> [Ethernet] Can't connect to the controller 	Connected to another Wi-Fi network	Disconnect from any wireless networks, and connect a cable from the controller directly to the device.
	Computing device has not had time to resolve the IP addresses	Depending on the speed of the device, it can take up to 1 minute for the device to allow communication to the Pro. Close any open browser windows, and reopen once connected.
<ul style="list-style-type: none"> Connected, but can't view the web interface 	Incorrect IP Address entered	If the controller's settings have not been changed, use the default IP: 169.254.145.50. If that does not solve the issue, review section 2.4.5. and reset the control to the defaults. Close the web browser window, open a new window, try the default settings.

6.0.1. Troubleshooting Network Issues Continued

ISSUE	POSSIBLE CAUSE	SOLUTION
<ul style="list-style-type: none"> Can't connect to the controller on a network 	[Wi-Fi] Router incompatible	The Wi-Fi router must be able to handle 802.11 b/g communication. The encryption MUST be either Open, WPA - TKIP, or WPA2 - AES. If trouble exists with the encryption, set the router to filter MAC addresses in open communication and add all the MAC addresses destined for the network. See 4.1.0. for the controller's MAC.
	Incorrect network settings	Consult an IT professional or system administrator to ensure the correct parameters are set in the controller for use on the network. If the settings were changed, the controller will be available at the new saved IP Address rather than the default.
<ul style="list-style-type: none"> Can't get into the settings 	Credentials were entered incorrectly	The User ID and password are case sensitive, and must be entered exactly as the defaults or saved value.
	Password was changed	If the password was changed and forgotten, follow section 2.4.5. to reset to the defaults. This will also reset any changed network parameters.

6.0.2. Troubleshooting Operation

ISSUE	POSSIBLE CAUSE	SOLUTION
<ul style="list-style-type: none"> Not Enough Hot Water Bad or no sensor readings in the control software 	Incorrect piping connections or dip tube lengths	Check the heat transfer appliance tank connections and ensure the hot goes into the top of the tank with a short or no dip tube, and the cold goes into the bottom of the tank, or the top with a long dip tube. Ensure the hot out of the tank to the fixtures is not shared with the solar equipment.
	Controller late or no turn on	Check the sensors and ensure they are contacting the piping or tank sufficiently and they are well insulated from the ambient temperatures to provide accurate readings.
	Improper wiring or loose connections	Ensure all the connections are placed in the proper input area i.e. the low tank sensor actually does connect to the controller at T2; wire colors are oriented in the proper terminals (Specifically Grundfos VFS and RPS sensors), the connectors are firmly connected and pressed all the way in or down, and all connections are metal to metal, no plastic or wire insulation can interfere for proper operation.
	Bad sensors or wiring	Use the Sensor Operational Test in 6.0.0. to determine if the thermistors are sending an appropriate reading to the controller.
	Sensor not installed	If the sensor reads a very low temperature in the range of -80°F to -110°F, the control is not receiving any signal from that sensor, i.e. it is not installed or installed properly.
<ul style="list-style-type: none"> Pump does not start 	Controller is in OFF position	Review section 2.4.4. If there is no jumper in the correct location, use the jumper located at JP5 for resetting the network parameters (No jumper at JP5 has no affect on the network parameters).
	No electricity to pump	Check the pump wiring to ensure pump(s) have correct wires at the terminals (i.e. white goes to N, green to ground, etc) and at the relay contacts. Measure voltage at the relay contact to determine if voltage is supplied. Ensure the unit is plugged in and the controller voltage switch is set to provide the correct voltage. Check the fuse to make sure it has not blown.
	Differentials are set too high	Adjust the differentials back to the defaults as described in section 4.2.1.
	Loose or bad contact	Clean contacts and firmly place connections, ensure metal to metal contact.
	Bad sensors or wiring	Use the Sensor Operational Test in 6.0.0. to determine if the thermistors are sending an appropriate reading to the controller.
<ul style="list-style-type: none"> Pump cycles on and off 	Minimal solar energy available	This can be normal operation in fall, winter and spring depending on the collector to storage ratio. To alleviate in these months: <ul style="list-style-type: none"> Set a higher ON differential Increase the usable collector temperature
	For open loop systems, the freeze protection may be set too high	Decrease the temperature at which the controller will recirculate hot storage water to prevent freezing; see section 4.2.1. to reset the default value.
	Bad sensors or wiring	Use the Sensor Operational Test in 6.0.0. to determine if the thermistors are sending an appropriate reading to the controller.
<ul style="list-style-type: none"> Pump runs continuously 	Controller is in ON position	Review section 2.4.4. and remove any unnecessary jumpers.
	Usable Collector Temperature is set too low	Increase the temperature at which the collector must reach to begin monitoring the differential function; see section 4.2.1. to reset the default, or increase the value.
	Bad sensors or wiring	Use the Sensor Operational Test in 6.0.0. to determine if the thermistors are sending an appropriate reading to the controller.

7. WARRANTY

Heliotrope Thermal DBA. HELIODYNE, shall provide a warranty for defects in compliance with the purchased goods delivered after 3/1/2008 as follows: the Delta-T and Delta-T Pro product (Products) to be free from defects in material and workmanship, and malfunctions and failure to perform, under normal use and service, for a period of three (3) years from date of installation, provided that said products have been installed in accordance with HELIODYNE's Installation Instructions. This warranty applies to the first retail buyer and to any subsequent owners.

In the event that evidence cannot be provided to indicate the date of installation, then the period of time shall be thirty six (36) months from the date of manufacture.

Objects are warranted at HELIODYNE's discretion by repair of the object of purchase or replacement of defective parts, exchange or reduction of price. The right of the contractor to convert objects is ceded by common consent. Replaced parts become the property of HELIODYNE. Wages and costs spent on installation and disassembly must be covered by the client. This provision similarly applies to all warranty agreements. It is at HELIODYNE's discretion to replace defective goods with similar, faultless goods. In this case, any rights to cancel the agreement cease. The client expressly waives the right for it and its legal successors to assert claims for damages or loss of profit (including without limitation special, indirect, loss of use, contingent, or consequential damages) due to defects or nonconformity in the purchased good. The warranty set forth above constitutes the sole and exclusive remedy against HELIODYNE for the furnishing of any nonconforming or defective goods. THE ABOVE WARRANTY IS EXPRESSLY IN LIEU OF ALL OTHER WARRANTIES, EXPRESS OR IMPLIED, INCLUDING WITHOUT LIMITATION ANY WARRANTY AS TO MERCHANTABILITY OR FITNESS FOR A PARTICULAR USE OR PURPOSE.

If the Product contains a defect that cannot be repaired after a reasonable number of attempts to do so, you, the buyer, may elect either a refund of its purchase price, or a replacement without charge. A replacement may consist of a new or factory rebuilt product of at least the same quality. A new warranty shall apply to any replacement.

Claims on warranty will only be admitted and considered if they are announced in writing immediately after the defect was first noticed. Oral communication or communication by telephone are not sufficient. To obtain service on the Product, notify Heliodyne Customer Service by email at sales@heliodyne.com, by letter to 4910 Seaport Ave., Richmond, CA, 94804. Provide proof of purchase and date.

Should service be requested and no defect found in the Product, then a reasonable charge will be made for the service.

In no event shall HELIODYNE be liable for the following:

- Conditions resulting from a defect in a component or part that does not make up the HELIODYNE Product.
- Conditions resulting from a significant departure from Heliodyne's Installation Instructions.
- Conditions resulting from any misuse, abuse, negligence, weather damage, accident or alteration.
- Consequential damages such as: damage to your property, loss of time, inconvenience or loss of use of the Product or any incidental expenses resulting from any breach of the express warranty. Conditions that may occur in the normal operation of the Product shall not be invoked by HELIODYNE to reduce or defeat the coverage of this warranty.

HELIODYNE's liability under this warranty shall be in lieu of all warranties of fitness and in lieu of all warranties of merchantability. Heliodyne shall not be liable for any incidental or consequential damages covered by a defective product. The maximum liability under this warranty shall not exceed the contract price of the Product. Some states do not allow the exclusion or limitations of incidental or consequential damages, and some states do not allow limitations on implied warranties, such as that of fitness and of merchantability. Therefore the above exclusions and limitations do not apply to you.

The warranty excludes damage caused by force majeure and malfunction that are due to improper assembly, and/or product installation. HELIODYNE is not liable for possible costs resulting from defects. In order for HELIODYNE to accept liability:

- Installation must have been carried out by a licensed specialized company (heating contractor or plumber) following the version of installation instructions in force;
- HELIODYNE or its representative was given the opportunity to check complaints on site immediately after any defect occurred;
- Confirmation exists that the system was commissioned properly and that the system was checked and maintenance was performed annually by a specialized company licensed for this purpose. The warranty agreed by HELIODYNE is only valid for their clients.

This warranty gives you specific legal rights, and you may also have other rights, which vary from state to state. Unless otherwise explicitly agreed in writing, it is understood that these are the only written warranties given by HELIODYNE, and HELIODYNE neither assumes nor authorizes anyone to assume for it any other obligation or liability in connection with the Product.

MOUNTING TEMPLATE

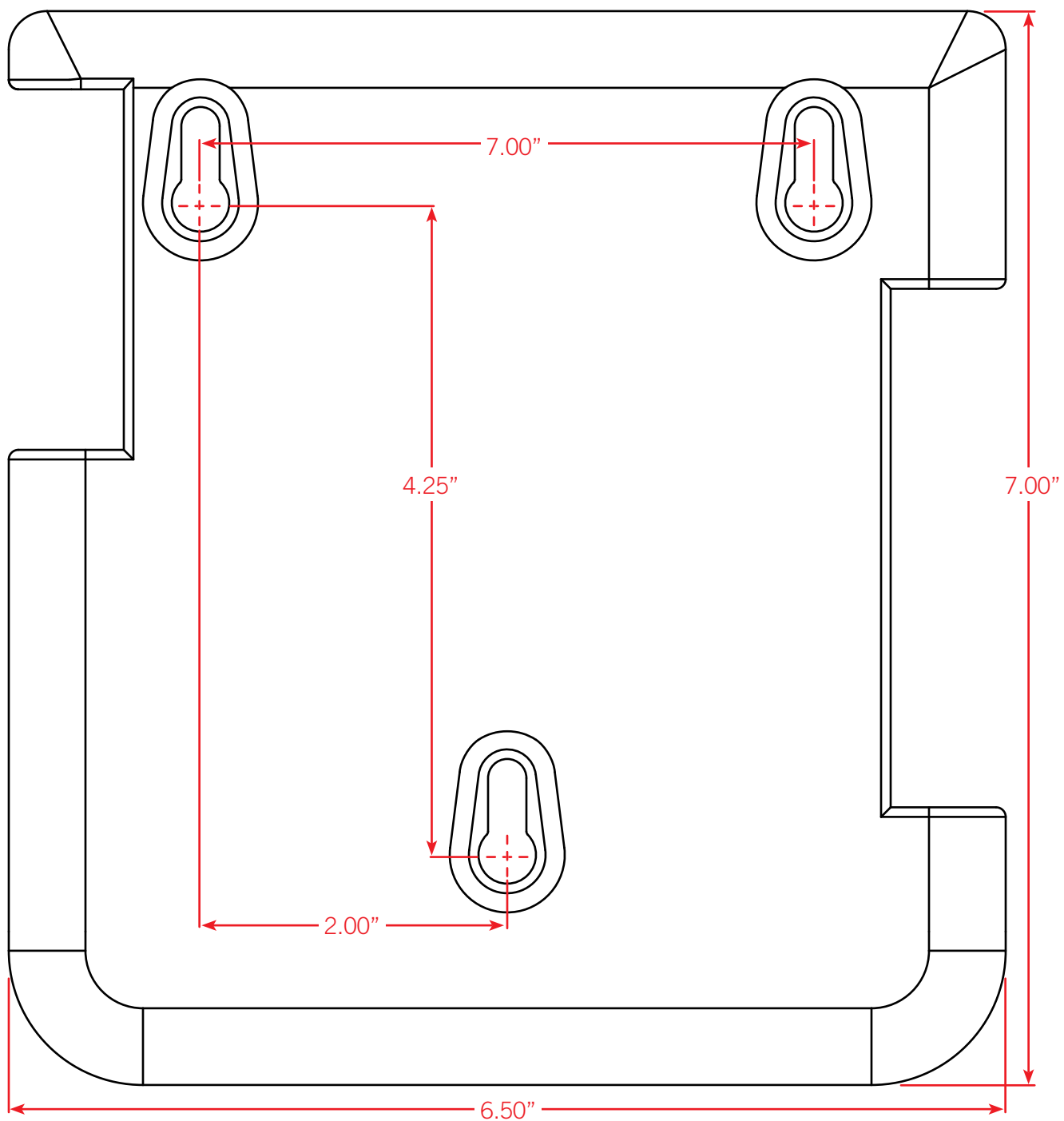

SCALE = 1:1

Heliodyne, Inc. • 4910 Seaport Avenue • Richmond, CA 94804
T: 510.237.9614 • F: 510.237.7018
www.heliodyne.com
Sales Inquiries: sales@heliodyne.com
Information and Support: info@heliodyne.com