



Remote Displays

RD100 WIRELESS and RD-WIRED

REMOTE READOUTS FOR THE T80 TurboCharger™



Monitor the PV – Battery System from anywhere

Battery system management in a convenient portable package. See what the PV array, Charge Controller, Batteries and Load are doing any time. Check the results for each day for the last 90 days.

Battery Energy Monitor Display is Essential

The T80 TurboCharger™ includes a built-in energy monitor based on TriMetric™ technology which tracks power production and consumption then calculates the energy remaining in the battery. State of Charge (SOC) is displayed in Percent Full, Amp-hours and bar graph format. This is the “gas gauge” that is essential in battery based systems. The T80 goes further by recording 90 days of historical data on energy production, usage, and number of days since fully charged. The Remote Display shows all the information at a glance at a convenient location.

- Displays comprehensive status of PV array, and Battery system
 - Battery State of Charge: % Full, Bar Graph, Watt-Hours and Hours Remaining
 - PV current and voltage
 - Battery charge/discharge Amps
 - 90 days of system history
- Wireless version:
 - 100 foot range in buildings
 - 300 feet outside (line of sight)
 - Repeater available
 - FCC approved.
 - Includes rechargeable batteries
- Wired version – CAT5 cable sends data and power from the T80
- Desktop or wall mount
- Transflective LCD with backlight

Wireless Option Card for the T80 TurboCharger™

The Wireless Network Option Card installed in the T80 Option Card slot comes with a chassis mount antenna.



Simple installation – No set up or programming

The wireless version couldn't be easier, just turn it on. The wired version is plug and play. Either Remote Display can be added to any T80 TurboCharger™ in the field.

Wireless Version RD100

The wireless board includes an internal antenna and rechargeable NiMH batteries with on board charging. Charging input may be 12v to 24v DC or 115VAC using the plug-in wall transformer.

Wired version RD-Wired

The Network Option Card provides the data and power for the Remote Readout using CAT5 cable.

SPECIFICATIONS

REMOTE DISPLAY – WIRED

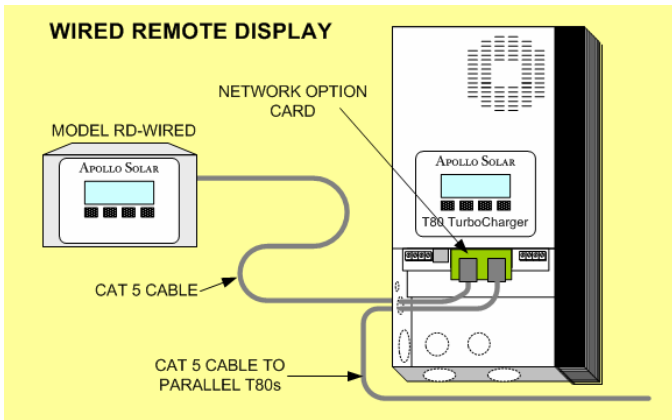

CAT5 port on T80 *TurboCharger*[™] Network Option Card provides 12 volts to power the Remote Display.

Cable Type CAT 5
 Maximum cable length 30m (100 ft)
 (Cable not included)

REMOTE DISPLAY – WIRELESS

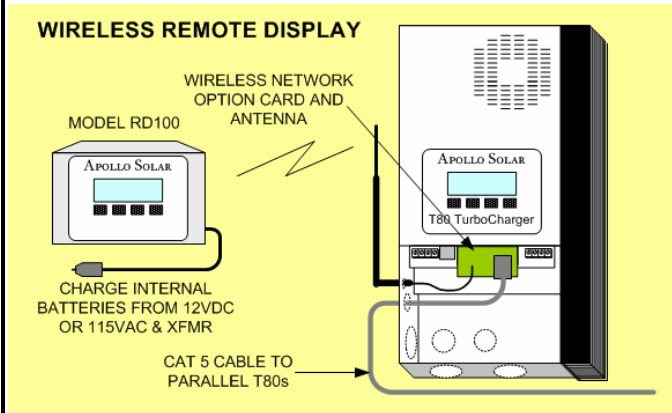

Range 30m (100ft) in buildings
 100m (300ft) line of sight
 Extended Range Repeater available
 Battery Life About 1 to 3 months depending
 on backlight usage
 Charger Input ... 12VDC to 24VDC or 115VAC

Remote Displays -- COMMON SPECIFICATIONS

Display type LCD 4 lines 20 characters Trans-flective with back light
 T80 Information Displayed SOC bar graph, SOC %, Amp-hours remaining,
 PV Input Voltage & Current, Battery Voltage & Current,
 Net battery charge / discharge current
 Charger history for 90 days
 Unit dimensions 18.5cm X 11cm X 6cm (7.3" X 4.3" X 2.4") Width X Height X Depth
 Shipping dimensions 28cm X 20cm X 18cm (11" X 8" X 7")
 Weight RD-Wired: 318gm (12oz) RD-100: 635gm (1.4lbs)
 Environmental rating Indoor Type 1 (Not intended for use in extremely damp locations)

Specifications are subject to change without notice. 2/07



23 F. J. Clarke Circle, Bethel, CT 06801
 (203) 790-6400 www.Apollo-Solar.net